

#N°1 français du service pour les laboratoires



SOLUTIONS TECHNIQUES & SERVICES
pour laboratoires
& industries

NOTRE ÉQUIPE EST COMPOSÉE D'EXPERTS, DE PASSIONNÉS,
DE TECHNICIENS, EN CONSTANTE FORMATION.

- PLUS DE 40 COLLABORATEURS
- PLUS DE 25 ANS D'EXPÉRIENCE
- UNE COUVERTURE NATIONALE



Retrouvez
tous nos équipements
et services sur

WWW.LABOANDCO.COM

DES CONSEILS POUR CHAQUE VENTE & SERVICE



AMÉNAGEMENT



Chaque laboratoire, entreprise ou industrie a ses enjeux, ses objectifs et ses contraintes. Les aménagements sont donc tous différents pour répondre à des problématiques toujours uniques. **Notre équipe est là pour comprendre votre besoin et vous accompagner au plus près.**

Labo and Co est à vos côtés pour l'établissement de votre cahier des charges, pour le suivi des travaux et leur réception et pour fournir le meilleur matériel et le plus haut niveau de service.



DISTRIBUTION

Labo and Co propose **des milliers de références d'équipement**, des plus simples aux plus complexes. Une équipe d'ingénieurs d'affaires et de techniciens, répartis dans toute la France, dispose d'une connaissance approfondie des équipements et mettent leur expérience à votre service. **Avant de conclure toute vente, nous nous assurons d'avoir compris tous vos enjeux.**

Nos partenariats et nos collaborations depuis des années avec **les plus grandes marques** vous garantissent une qualité sans faille.



SERVICES

DES INTERVENTIONS SÉCURISÉES ET CERTIFIÉES

Une réactivité essentielle

Chez Labo and Co, nous savons à quel point le dysfonctionnement d'un équipement peut avoir des répercussions catastrophiques sur des recherches ou sur une production.

Des techniciens pleinement habilités

Nos équipes disposent des habilitations requises : manipulation des fluides frigorigènes, habilitations électriques, risques chimiques, etc... Pour des interventions conformes et sécurisées.

Une offre complète et flexible

Notre large éventail de services nous permet de répondre à toutes vos problématiques, qu'il s'agisse d'un besoin ponctuel ou récurrent.

Vos essais externalisés sont effectués dans notre propre laboratoire par nos équipes spécialisées

- QUALIFICATION & INSTALLATION
- MÉTROLOGIE & ÉTALONNAGE
- RECONDITIONNEMENT
- RÉPARATION & ENTRETIEN (ÉLECTRIQUE, MÉCANIQUE ET FROID)
- LOCATION
- ESSAIS EXTERNALISÉS



CERTIFICATIONS

Labo and Co est **certifié pour garantir à ses clients des prestations fiables, traçables et conformes aux normes** les plus exigeantes du secteur du laboratoire et de l'industrie.

- ▶ **Certification ISO 9001** – Qualité et fiabilité de nos services
- ▶ **Certification CEFRI n°1616E** – Interventions en zones réglementées

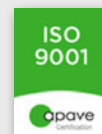

Découvrez la Location Longue Durée

Une solution flexible et sécurisante pour équiper votre laboratoire en toute sérénité : Mise en service, maintenance, SAV, extensions de garanties, la solution clé en main !



@ contact@laboandco.com

www.laboandco.com

+33 1 45 98 74 80

FEDEGARI

**SMART
EXCELLENCE
LAB SOLUTIONS**



**BE.Engineered
FVA**

SMART **EXCELLENCE**

EXCELLENCE. It is the legacy of Fedegari - engineering mastery and unwavering reliability.

SMART. It is the present and future of LAB - accessible, immediate, and designed to empower both customers and dealers.

KNOWLEDGE is both the foundation and the goal: just as Fedegari's know-how gave life to LAB, LAB translates precision, reliability, and ingenuity into tangible solutions.

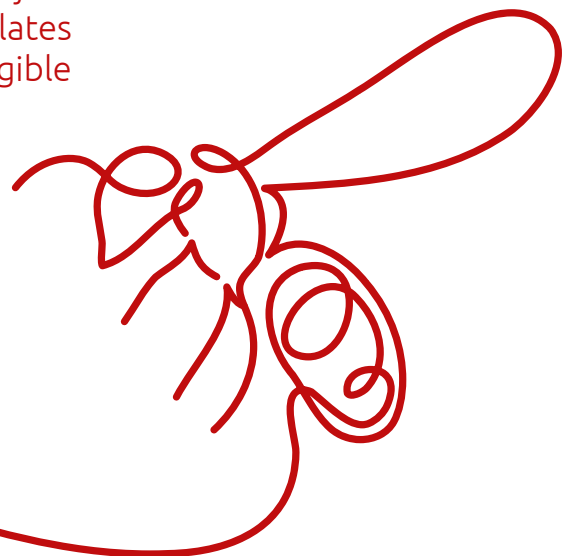

WHY:

Everything we do is driven by the belief that scientific research and technological innovation can improve people's lives.



HOW:

We achieve this by empowering our partners with deep expertise, cutting-edge technologies, and high-value solutions.



WHAT:

We make collaboration effortless - we stay close to the market, offer configurable solutions, and provide expert training as true masters of sterilization.

WHERE TECHNOLOGY MEETS DESIGN

The power of
Fedegari's expertise
faster, simpler,
smarter.

FVA autoclaves are engineered to deliver smart, efficient, and **user-friendly** sterilization solutions across a wide range of applications.

Designed with both functionality and aesthetics in mind, they combine cutting-edge technology with **intuitive usability**.

Built for fast and cost-effective processes, these autoclaves **simplify sterilization processes without compromising quality or reliability**.



In pharmaceutical R&D, microbiology labs, QC departments, and the food and cosmetics industries, sterilization must:

- ④ Ensure effective microbial inactivation.
- ④ Preserve the integrity of samples and containers.
- ④ Avoid cross-contamination and environmental release.

- ④ Comply with standards (FDA 21 CFR Part 11, EN285, Pharmacopeia).

Users need a flexible, safe, and compliant autoclave that can handle different loads and risk levels.

BE.ENGINEERED



EQUIPMENT CONFIGURATION

FVA SIZE

- 75 L – 2.65 ft³
- 140 L – 4.94 ft³
- 188 L – 6.64 ft³

(for additional information refers to dimensions section at pag.18)

PRESSURE VESSEL CERTIFICATION

- ASME
- PED
- SELO
- PED+CUTR32 (Russia)
- PED+CEOC
- ASME+NR13
- PED+NR13
- NR12
- BSPD.5500

Easy maintenance to guarantee long-term efficiency and consistent performance.

Designed for operator safety with a horizontal opening lid that enhances ease of use and protection.

Versatile for special applications: counter-pressure for heat-sensitive products, fast cooling for culture media and liquids, decontamination for different types of waste.

Ensure full regulatory compliance.

Offer validated, repeatable sterilization cycles.

SMART STERILIZATION, SAFE RESULTS: EVERY CYCLE, EVERY TIME

SOLID POROUS CYCLE

When it comes to sterilizing solid materials such as glassware, machine parts, hollow or porous items, precision and consistency are essential. This cycle leverages a **single-stage liquid ring vacuum pump** capable of reaching a vacuum level below 70 MBAR, in line with EN285 requirements, performing two critical actions:

- ⬡ Efficiently removes air from the load, ensuring proper steam penetration.
- ⬡ Thoroughly dries the materials at the end of the cycle.



This makes it ideal for preparing labware that must be immediately clean, dry, and ready for sterile operations.

OPEN LIQUIDS CYCLE

Sterilizing liquids in open or loosely capped containers demands special care to avoid spillage and ensure **uniform heat penetration**. This cycle leverages a combination of:

- A fan installed on the chamber ceiling for active air movement.
- Cooling water circulating through the chamber plates.
- A final slight injection of sterile compressed air as counterpressure.

Together, these elements rapidly cool the load while maintaining internal container pressure, preventing boil-over and preserving sample integrity.

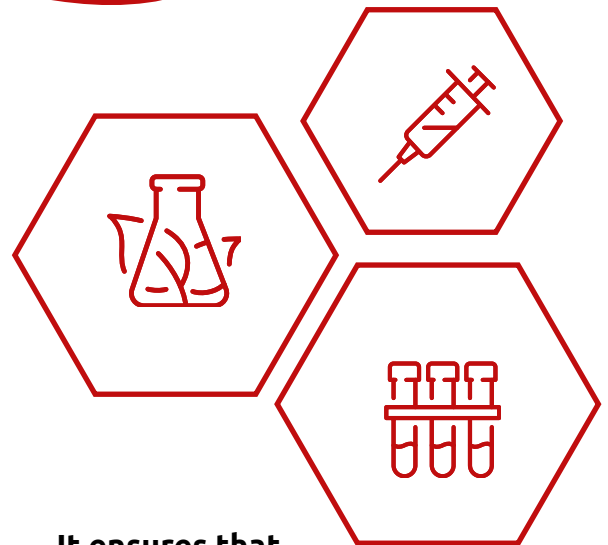

CLOSED LIQUIDS CYCLE

For hermetically sealed or deformable containers such as bags or pre-filled syringes, where pressure differences during sterilization can lead to container deformation or rupture. This cycle leverages **steam-air counterpressure** throughout the entire process:

- Maintains balanced internal and external pressure on containers.
- Prevents deformation and guarantees the integrity of the product.

It ensures that even the most delicate liquid formats can be safely and effectively sterilized.

DECONTAMINATION CYCLE

LOW PATHOGEN

When sterilizing solid or porous materials potentially contaminated with microorganisms of group **MOG1** or **MOG2** (no high pathogen risk), ensuring **environmental safety** is paramount. This cycle leverages an advanced filtration system and controlled exhaust to deliver:

- Absolute retention filtration: 0.22 µm for liquids and 0.003 µm for gases.
- Safe removal of air via vacuum pump through sterilizing-grade filters.
- Steam injection into the exhaust line, ensuring decontamination of condensates.



Except from the air removed by the vacuum pump, no other fluid is released into the environment until the cycle concludes successfully, providing maximum safety in handling low-to-moderate risk biological materials.

HIGH PATHOGEN

Designed for high-risk biological waste, such as **MOG3/MOG4** microorganisms, this cycle ensures complete containment and neutralization of hazardous materials. It is especially effective for **liquid or aqueous waste**. The cycle leverages a closed-loop sterilization approach:

- No discharge of air or condensate until the cycle ends with validated results.
- Steam introduced into both the chamber and the exhaust to ensure all surfaces and condensates are sterilized.
- Optional high-temperature kit allows operation up to 137°C /278°F for challenging loads.



This cycle is ideal where maximum environmental and operator protection is non-negotiable. No fluid is released into the environment until the cycle concludes successfully, providing maximum safety in handling high risk biological materials.

SPECIAL CYCLES

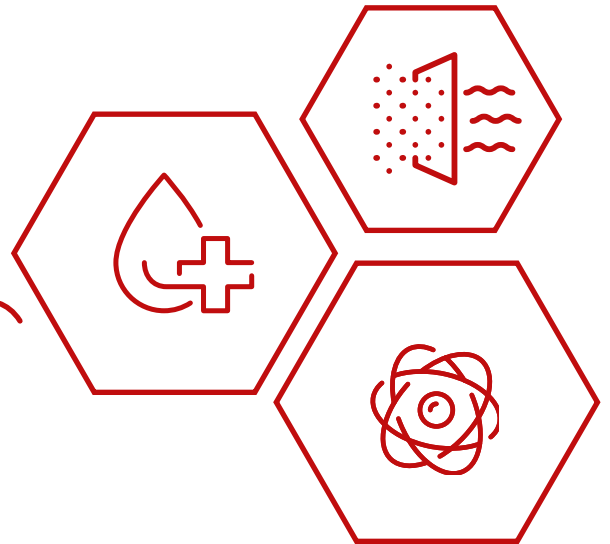
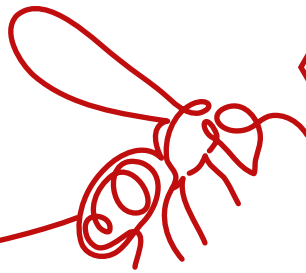

SLOW VACUUM

Some highly **sensitive materials**, such as **delicate membranes** or fine-pore filters, require a more gradual removal of air to avoid structural damage. This cycle performs a carefully controlled vacuum phase:

- Applies a gentle vacuum process.
- Protects fragile components without compromising sterilization effectiveness.

HIGH TEMPERATURE DESIGN

When temperature in counterpressure is required to be **higher than 128° C /262°F**. This configuration:

- Extends maximum counterpressure temperature to 137°C /278°F.
- Requires dedicated hardware kit.

F₀ CALCULATION

Heat-sensitive products, such as food samples or pre-filled syringes (PFS), require **precise thermal dosing** to ensure effective sterilization without compromising the product. This optional software feature enables:

- Real-time F₀ value calculation from temperature probe data.
- Controlled exposure above threshold to prevent damage.

PASTEURIZATION CYCLE (FOOD)

Certain foods require gentle heat treatment to **preserve** their original taste, texture, and nutritional value. This cycle ensures effective pasteurization **without compromising quality**:

- ⬡ **Maintains temperatures between 60°C and 105°C (140°F–221°F).**
- ⬡ **Preserves organoleptic, chemical, and physical properties.**
- ⬡ **Ideal for sensitive food products needing low-temperature processing.**



CYCLE REPETITION (used also for stress test)

For testing or unattended operation, this function enables **automatic repetition** of the last selected program:

- ⬡ **Repeats the previous cycle without operator input.**
- ⬡ **Ensures consistency and reliability in repeated processes.**

WARM UP – WARM KEEPING PROGRAM

Designed for applications requiring **stable thermal conditions**, such as culture media preparation:

- ⬡ **Maintains a set temperature between 40°C and 105°C (104°F–221°F).**
- ⬡ **Ensures thermal stability over a defined period.**
- ⬡ **Supports precise preparation of loads that must be warm before use.**

TEST & COMPLIANCE

Ensuring process integrity and regulatory compliance are essential for any QC or microbiology lab. Fedegari provides a comprehensive set of testing and validation tools to meet the most stringent standards:

Vacuum Test

This test checks the **chamber's tightness** under vacuum conditions to ensure there are no leaks, fully conforming to EN285 standards.

Pressure Test

Conducted with the chamber pressurized, this test ensures **mechanical integrity** and verifies that the chamber meets EN285 compliance for pressure resistance.

Bowie-Dick Test

Designed specifically for porous loads, this test verifies **efficient air removal and proper steam penetration**, as required by EN285.

Pharmacopoeia Tests

To support compliance and validation, the autoclave can perform specific tests, including:

- ⬡ Glass resistance
- ⬡ Alkalinity test
- ⬡ Stopper integrity

EN285 Full Compliance Kit

The unit is fully equipped with a compliant vacuum pump, air filter, and start-stop relays. Optional accessories include an independent recorder and printer to support documentation needs.

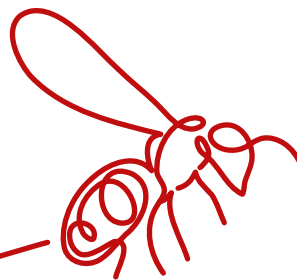

DIGITAL CONNECTIVITY & DATA MANAGEMENT OPTIONS

Digital integration and data management play a crucial role in microbiology and quality control laboratories. From compliance with data integrity regulations to seamless process monitoring and traceability, these features empower labs to meet modern operational and regulatory demands efficiently.

Remote Graphic User Interface (GUI)

This feature enables **remote access** to the autoclave via the Ethernet port. Users can monitor operations and save machine parameters in PDF format for documentation.

FDA 21 CFR Part 11 Compliance

A software option ensuring full compliance with 21 CFR Part 11, including audit trail capabilities, change logs, and detailed user access control.

SCADA Connectivity (Read-Only)

Fedegari offers read-only integration with customer LIMS/SCADA systems via two protocols:

- ⬡ MODBUS TCP/IP
- ⬡ OPC UA



SCADA Read & Write Integration

For **advanced control needs**, this option allows select machine parameters to be controlled directly from the customer's SCADA system.

Cycle Report in PDF (via USB)

Operators can **export complete cycle reports** directly to a USB key in PDF format from the HMI.

Electronic Signature for 21 CFR Part 11

Meets the latest **regulatory standards** (21 CFR Part 11 §11.3 and Annex 11) by enabling digital signature functionality as a legally binding equivalent to a handwritten signature. Requires SNTP synchronization.

SNTP Synchronization

Enables synchronization of the autoclave's internal clock with an external time server to maintain traceable, accurate timestamps.

LDAP – Remote Authentication

Supports centralized management of user credentials via LDAP, **enhancing security and administrative control**. Requires SNTP synchronization.

Automatic Backup

Allows scheduled backups (daily, weekly, or monthly) of all relevant machine data and settings. **Backup files** include parameters, calibrations, user lists, and history logs, and can be saved via USB or Ethernet connection to a server.

UTILITIES

⬡ **Water tank for steam generator feeding in case of absence of a dedicated water line/tank**

It is required where there are no dedicated water line at customer's site.

⬡ **Steam generator**
(not available for FVA3/A1 plus)

It is required when a clean steam line is not available at the installation site.

⬡ **Steam generator PLUS**
Clean water-fed steam electric generator or 9 kW constructed in AISI 316L stainless steel.

⬡ **Clean steam line connection**
Used if clean steam line is present at the site.

⬡ **Internal air compressor**

It is needed only for the lid gasket and pneumatic valves when pressurized air is not required for liquid treatment. If a compressed air supply is not available at the installation site, the sterilizer can be equipped with an oil-free electric piston compressor. This compressor is installed into the cabinet and is provided with an accumulation tank made of 304 stainless steel with a capacity of 2 liters.

⬡ **Drain cooler 70°C/158°F**

It is used when tubes don't tolerate high temperatures. To cool the discharged fluids to lower temperatures, an optional compact air condenser can be installed, ensuring a final temperature below 70°C/158°F.

ADDITIONAL HARDWARE OPTIONS

⬡ **Thermal printer on board**
It is a thermal paper printer directly connected to the autoclave control panel, whose primary function is to document, in real time and at a programmable rate, the execution of the sterilization program in progress.

⬡ **Nanodac paperless recorder**
The data is recorded by an independent recorder. It is needed when regulations require creating an **independent record of the cycle data**. It includes an external recorder signal, a dedicated pressure transducer and a probe.

⬡ **Validation port adapter**
It is a port adapter, needed when the insertion of **additional temperature probes / pressure transducer in the chamber** is required.

⬡ **Additional probe (PT100)**

⬡ **Safety Thermolock**
It is an additional safety device with an additional probe not connected to the process controller but to a safety locking device.

⬡ **Start/stop signal for independent recorder (no probe)**

⬡ **Dry contact for steam generator water feeding loop**

⬡ **Electric lifting device 30 kg / 30 kg PLUS / 100kg PLUS**



DOCUMENTATION

- SAT protocols
- IQ/OQ protocols
- PQ protocols
- Certificate of origin
- Chamber Of Commerce stamped invoice
- Document hard-copy, instead of PDF
- Document PDF copy
- P&ID as built
- Electrical Wiring Diagram as built
- Installation drawing as built
- Software assurance statement
- Additional documentation – instruments/filters certificate, construction materials, pressure vessel welding & roughness/passivation statement



ACTIVITIES

- FAT execution
- Start-up, commissioning & training
- IQ/OQ execution
- PQ execution
- Instrument calibration
- Temperature mapping
- Special activities: technical center tests

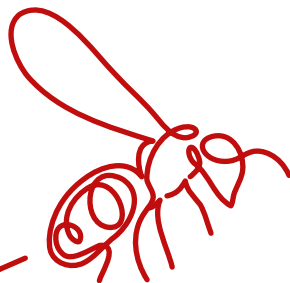

ACCESSORIES

- 304 stainless steel wire basket
- Silicone basket

FVA

DIMENSIONS, VOLUME AND POWER

MODEL	FVA2/A1	FVA3/A3	FVA3/A1 PLUS
CHAMBER DIMENSIONS (mm)	Ø 405 x 600 H	Ø 505 x 700 H	Ø 505 x 940 H
CHAMBER DIMENSIONS (in)	Ø 15.94 x 23.62 H	Ø 19.88 x 27.56 H	Ø 19.88 x 37 H
TOTAL EXT. DIMENSIONS (mm)	1242Wx600Dx1305H	1242Wx600Dx1305H	1242Wx853Dx1540H
TOTAL EXT. DIMENSIONS (in)	48.90Wx23.62Dx51.38H	48.90Wx23.62Dx51.38H	48.90Wx33.58Dx60.63H
USEFUL CHAMBER VOLUME (L)	75	140	188
USEFUL CHAMBER VOLUME (ft3)	2.65	4.94	6.64
POWER REQUIRED	6,5 KW	7,5 KW	9,5 KW

UTILITIES REQUIREMENTS

UTILITIES REQUIREMENTS	EXTERNAL STEAM INLET	WATER INLET	COMPRESSED AIR INLET	PURIFIED WATER INLET
Type of fluids	Pure steam	Water to feed the vacuum and chamber cooling pump	Dry and deoiled air to feed the air valves and charging set in the chamber	Purified water (subject to deionization or osmosis) Conductivity: 1 ÷ 30 µS/cm (suggested 15 µS/cm) at 25°C/77°F TOC < 500 ppb pH: 6.0 ÷ 7.5 Chloride max 30 ppm
Pressure	4 ÷ 4,5 bar 58,02 ÷ 65,27 psi – 12 kg/h 26.46 lb/h	2.5 ÷ 4,5 bar 36.26 ÷ 65.27 psi Water hardness max 20°FH	6 ÷ 8 bar 87,02 ÷ 116,03 psi	1 ÷ 4 bar 14.5 ÷ 58.02 psi

POWER

- 230V/50Hz +PE (three-phase + earth)
- 230V/60Hz +PE (three-phase + earth)
- 400V/50Hz +N +PE (Standard) (three-phase + neutral + earth)
- 400V/60Hz +N +PE (three-phase + neutral + earth)

TECHNICAL DRAWINGS

FVA2/A1 - FVA3/A1

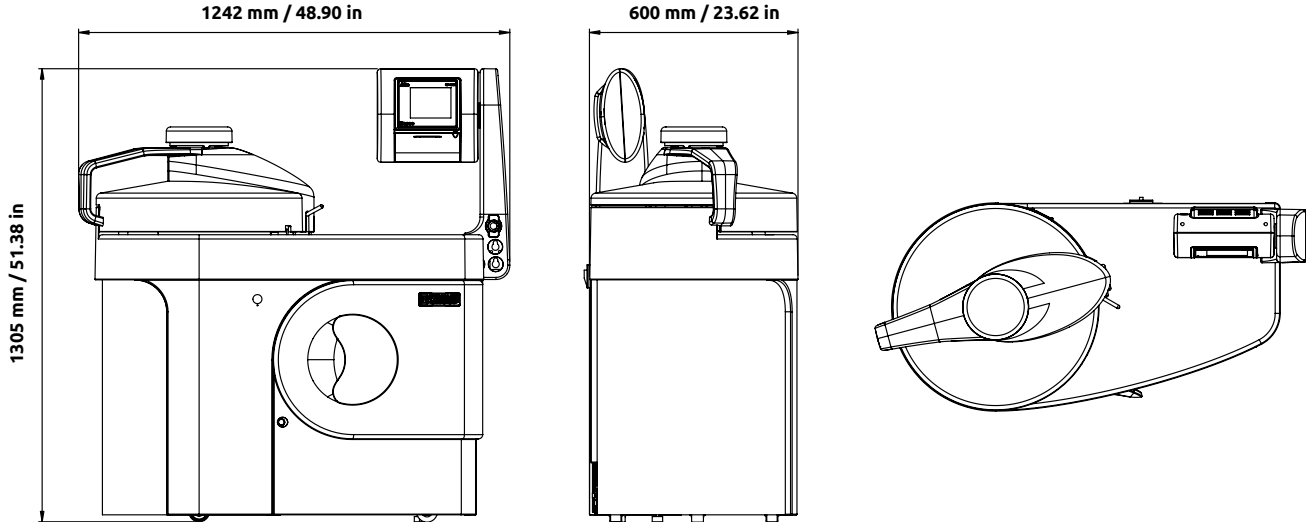

FVA3/A1 PLUS

